

LED PACKAGE FOR NANO COVE / NEW POWERFLEX

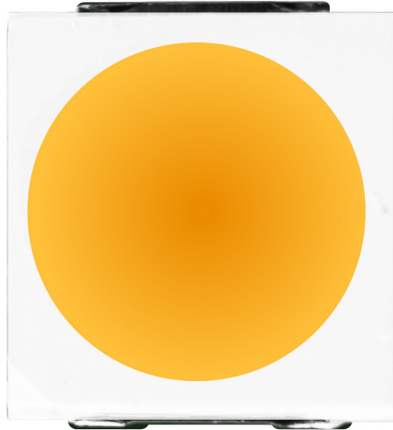

Features

- Small package with high efficiency
- Low voltage operation, instant light
- Long operating life
- Lead-free product
- RoHS compliant

Applications

- Architectural / Decorative Lighting
- Landscape lighting lamp

Package Dimensions

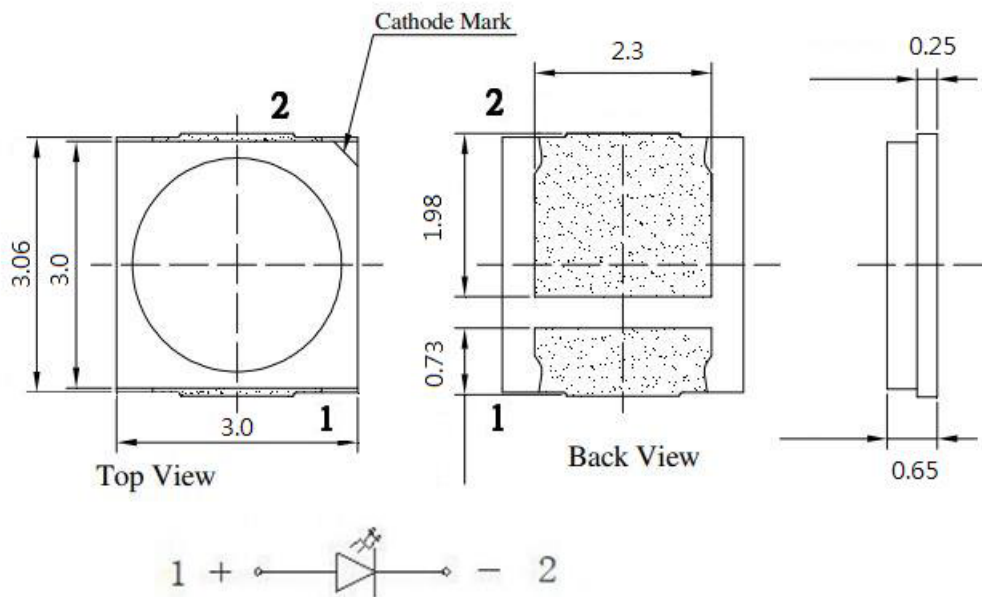

NOTE1: All dimensions are in mm

NOTE2: Tolerance is ± 0.15 mm unless otherwise noted.

ELECTRICAL/OPTICAL SPECIFICATION

T_j=25°C

ITEM	SYMBOL	CONDITION	MIN.	TYP	MAX.	UNIT
Forward Voltage	VF	If=180mA	2.8	-	3.2	V
Reverse Current	IR	Vr=5V	0	-	5	μA
Luminous Intensity	IV	If=180mA	14,000	-	28,000	mcd
Luminous Intensity	LM	If=180mA	40	-	80	lm
View Angle	2θ 1/2	If=180mA	-	120	-0	degree
CRI		If=180mA	95			
R9		If=180mA	90			

NOTE: Please refer to CIE 1931 chromaticity diagram

ABSOLUTE MAXIMUM RATINGS

T_j=25°C

ITEM	SYMBOL	MAXIMUM RATING	UNIT
Forward Current	If	300	mA
Pulse Forward Current*	Ifp	400	mA
Reverse Voltage	Vr	5	V
Power Dissipation	Pd	950	mW
Operation Temperature	Top	-30 ~ +85	°C
Storage Temperature	Tstg	-40 ~ +100	°C
Soldering Temperature	Tsld	Reflow Soldering: 260°C/10sec Hand Soldering: 350°C/3sec	

*Duty Cycle < 1/10 ; Pulse Width < 10 msec.

NOTE: Subjecting the part to stresses beyond listed under this section may cause permanent damage to the device. These are stress ratings only and do not imply that the devices will function beyond these ratings. Exposure to the extremes of these capabilities.

CIE COLOR RANK

1800K

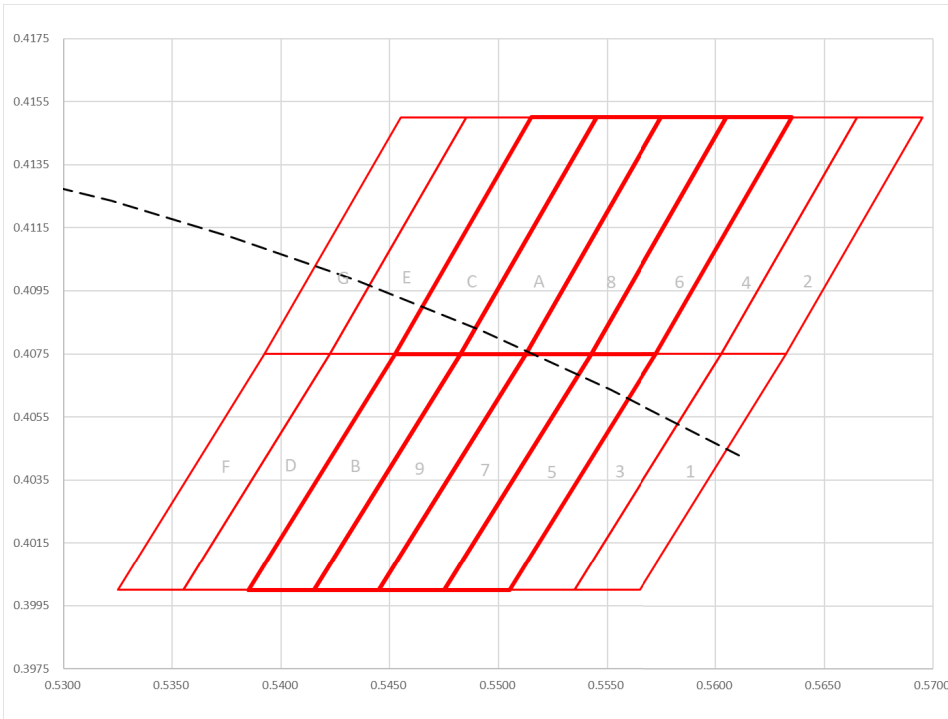

NOTE: CIE Chromaticity Diagram for ANSI

2200K

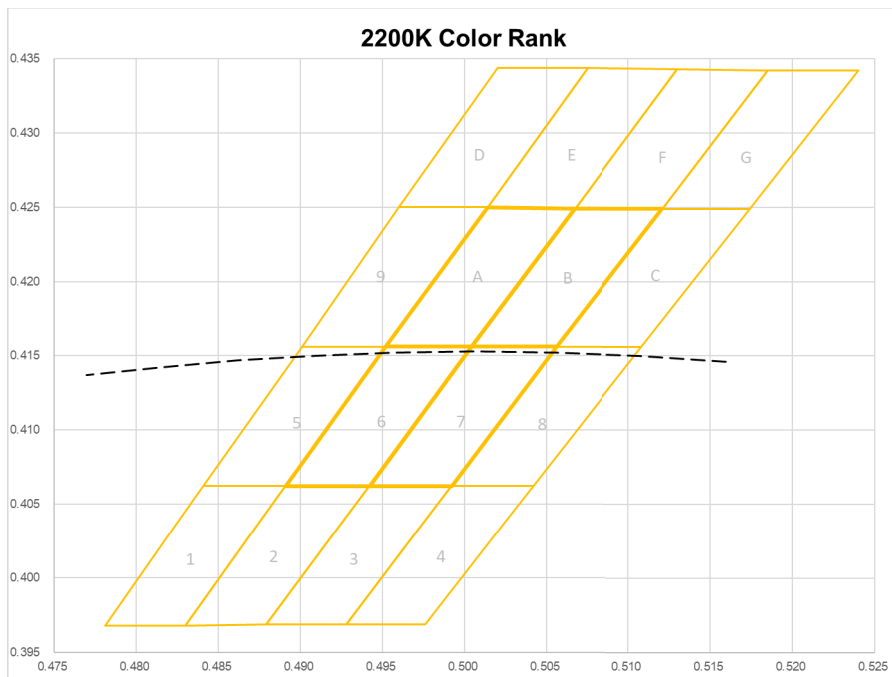

NOTE: CIE Chromaticity Diagram for ANSI

2700K

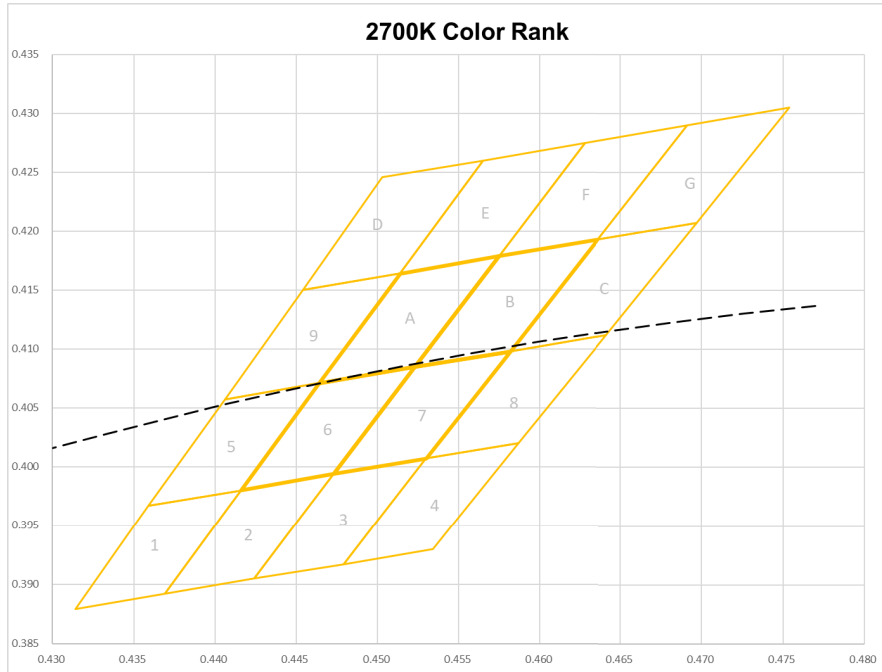

NOTE: Measurement Uncertainty of the Color Coordinates: ± 0.01

3000K

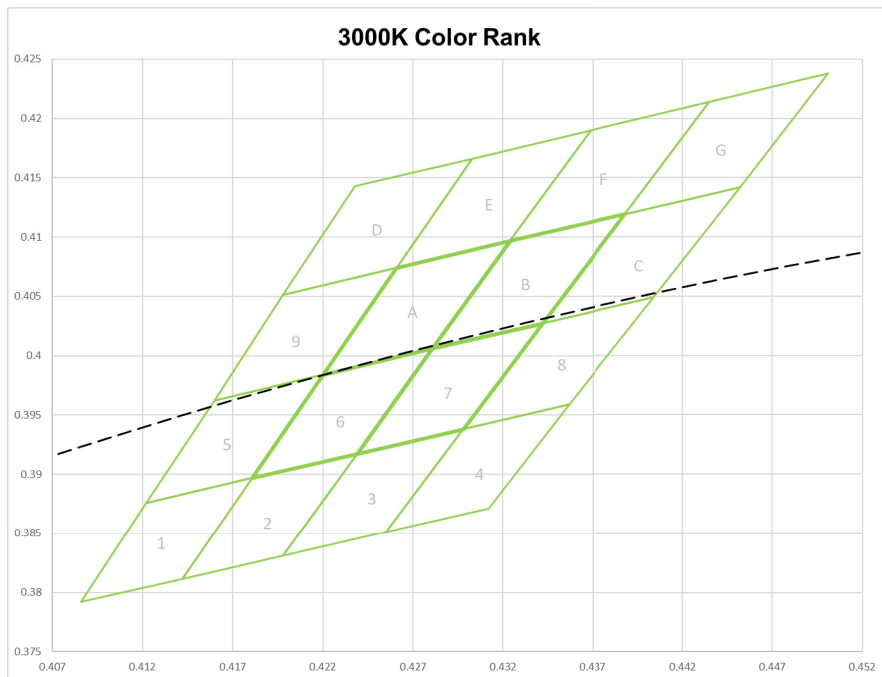

NOTE: Measurement Uncertainty of the Color Coordinates: ± 0.01

3500K

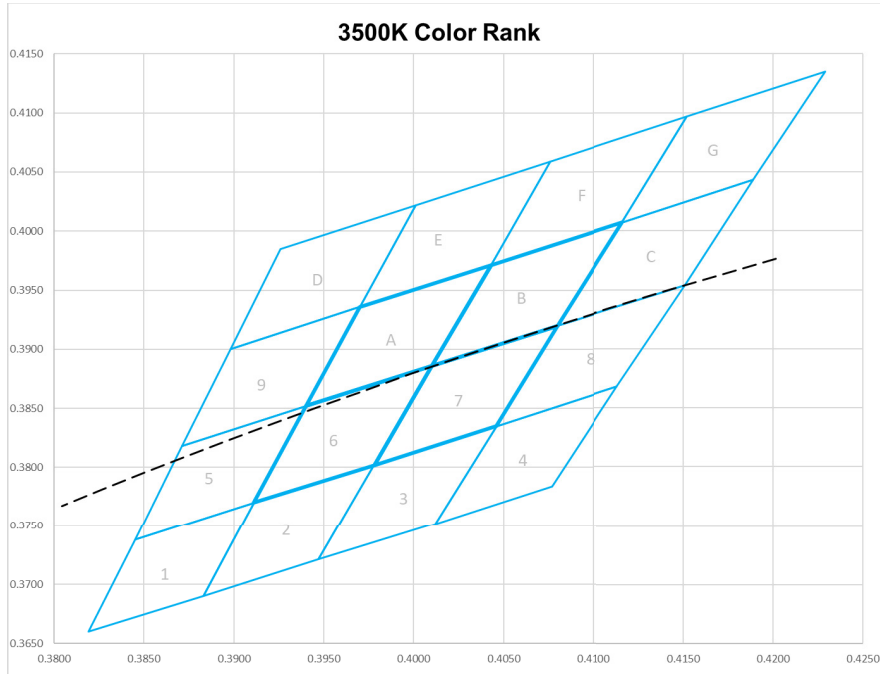

NOTE: Measurement Uncertainty of the Color Coordinates: ± 0.01

4000K

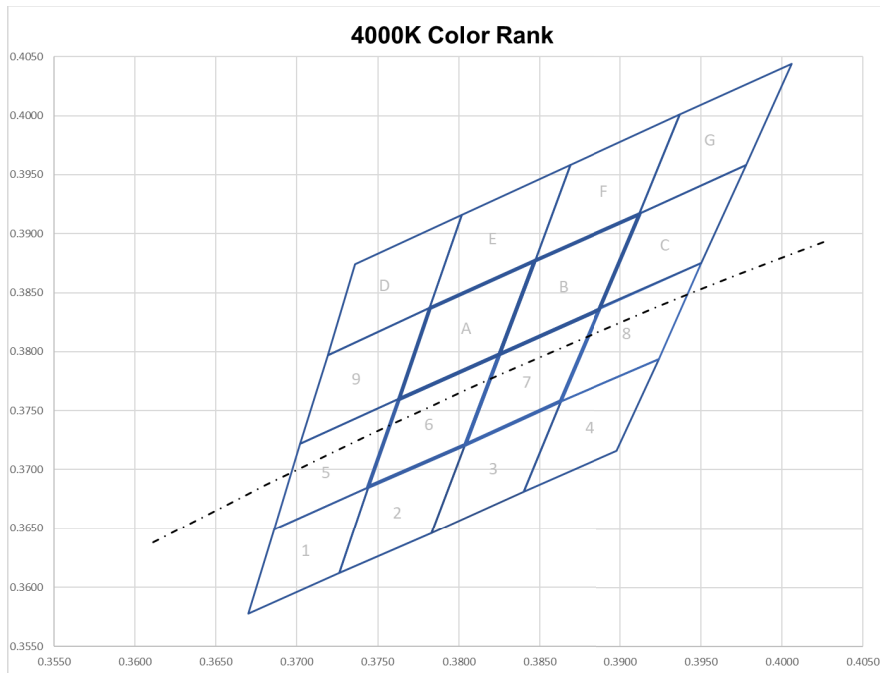

NOTE: Measurement Uncertainty of the Color Coordinates: ± 0.01

6500K

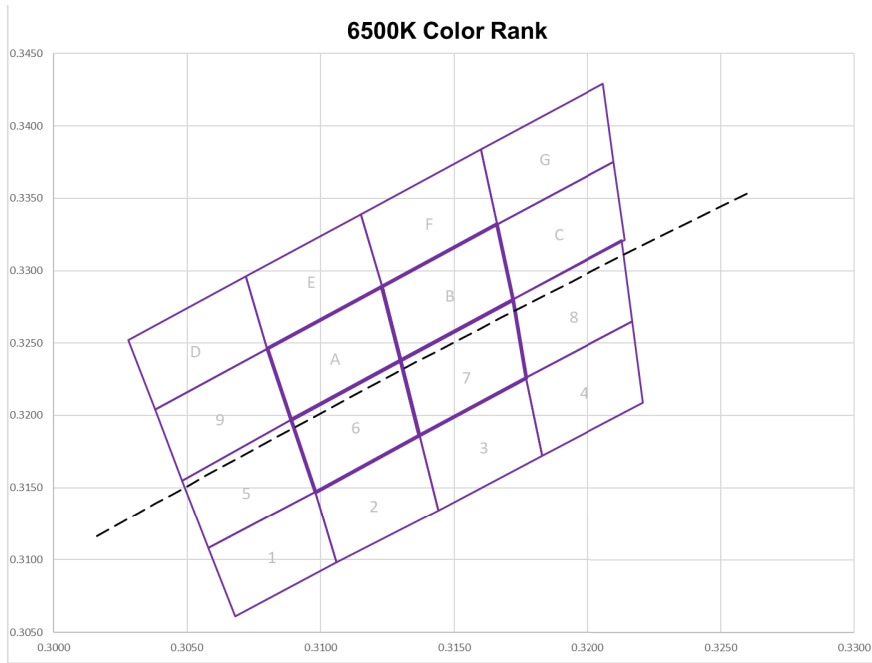

NOTE: Measurement Uncertainty of the Color Coordinates: ± 0.01

FORWARD VOLTAGE RANKS

Forward Voltage Measured at if + 180mA **T_j=25°C**

VF CODE	MIN. (V)	MAX. (V)
2.8	2.8	3.0
3.0	3.0	3.2

NOTE: Forward Voltage Measurement Tolerance is ± 0.05

LUMINOUS INTENSITY RANKS

Luminous Intensity Measured at if + 180mA **T_j=25°C**

LM CODE	MIN. (lm)	MAX. (lm)
40	40	45
45	45	50
50	50	55
55	55	60
60	60	65
65	65	70

NOTE: Luminous Intensity Measurement Tolerance is ± 10%

MAIN BIN

T_j=25°C

TYPE	FLUX (LM)	CIE RANK			
		A6	A7	AA	AB
A (1800K)	≥ 40	A6	A7	AA	AB
Y (2200K)	≥ 45	Y6	Y7	YA	YB
W (2700K)	≥ 60	W6	W7	WA	WB
V (3000K)	≥ 60	V6	V7	VA	VB
U (3500K)	≥ 65	U6	U7	UA	UB
T (4000K)	≥ 65	T6	T7	TA	TB
P (6500K)	≥ 70	P6	P7	PA	PB

MATERIALS

ITEM	MATERIALS
Package	Heat Resistant Polymer
Encapsulating Resin	Silicone Resin (with Phosphor)
Electrodes	Ag Plating Copper Alloy

RADIATION CHARACTERISTICS

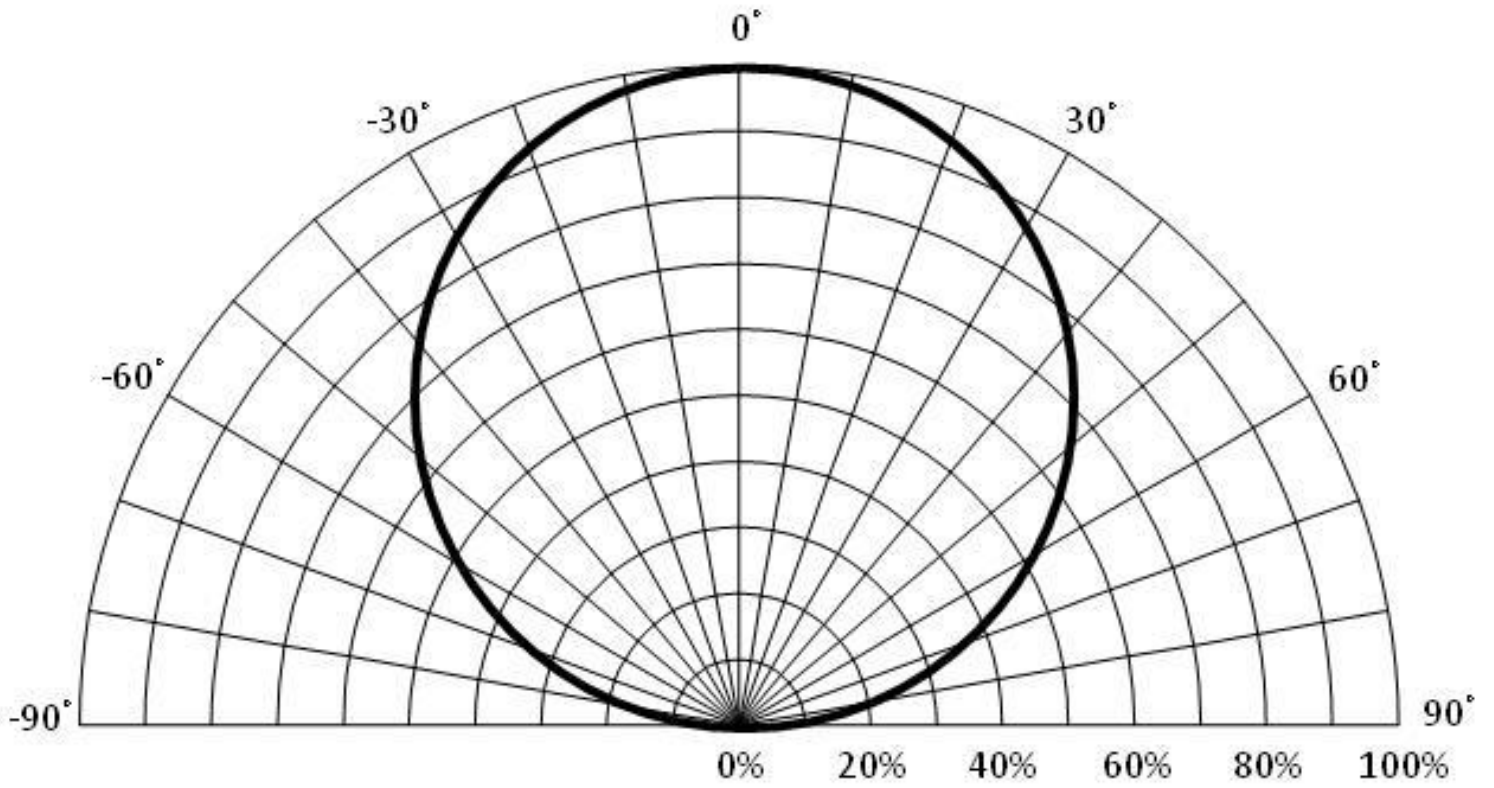

OPTICAL/ELECTRICAL CHARACTERIZATION

Relative Luminous vs. Forward Current

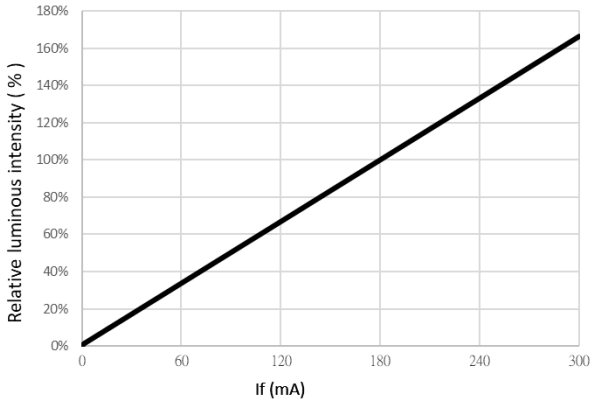

Forward Voltage vs. Forward Current

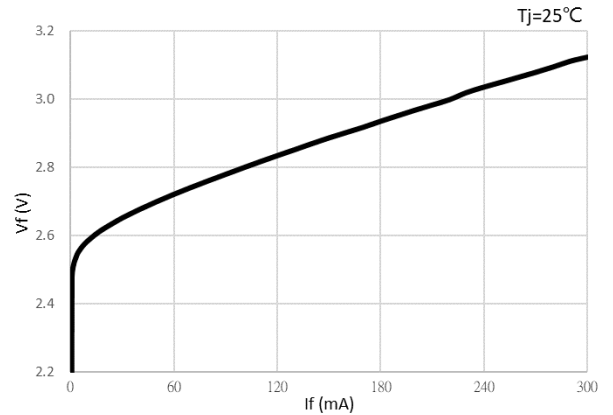

Forward Voltage vs. Ambient Temperature

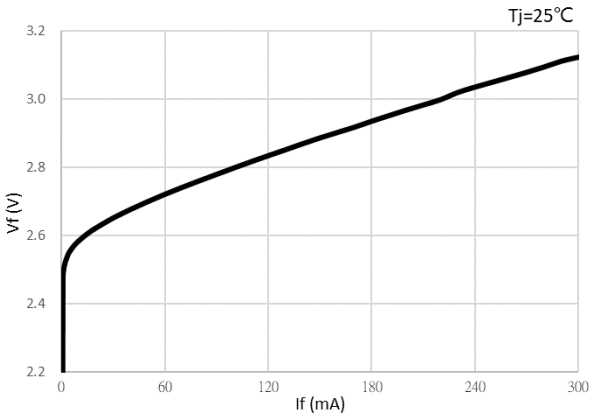

Relative Luminous vs. Ambient Temperature

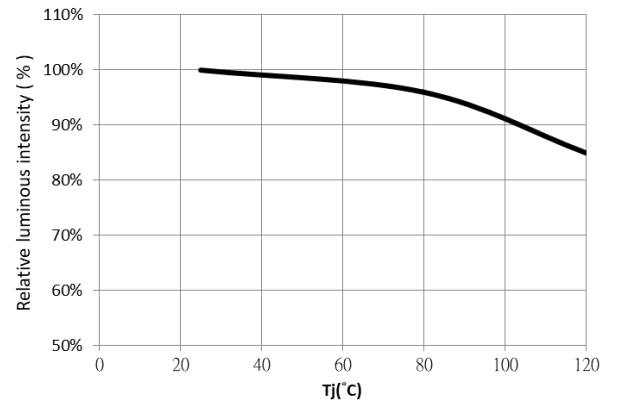

OPTICAL ELECTRICAL CHARACTERIZATION SPECTRUM 1800K/2200K/2700K

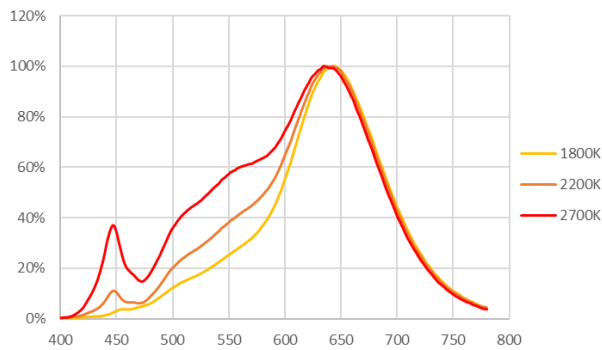

3000K/3500K/4000K/6500K

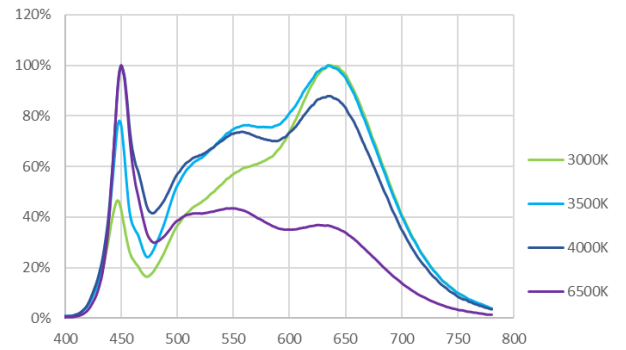

PACKING INFORMATION

Embossed Tape Dimension

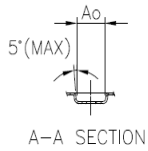
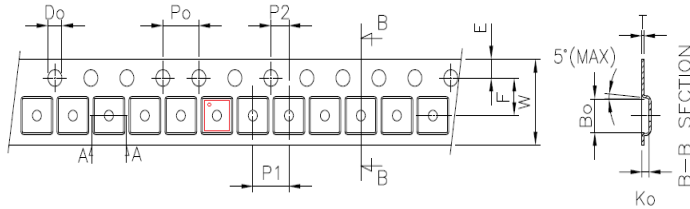

Unit: mm

Symbol	Ao	Bo	Ko	Po	P1	P2	T
Spec	3.24±0.10	3.24±0.10	0.80±0.10	4.00±0.10	4.00±0.10	2.00±0.05	0.20±0.05
Symbol	E	F	Do	D1	W	10Po	
Spec	1.75±0.10	3.50±0.05	1.50 ^{+0.10} ₋₀	1.00 ^{+0.10} ₋₀	8.00±0.30	40.0±0.20	

NOTE 1: Dimensions are in millimeters

NOTE 2: Dimensions conform to JIS-C-0805 and EIA-481

Reel Dimension

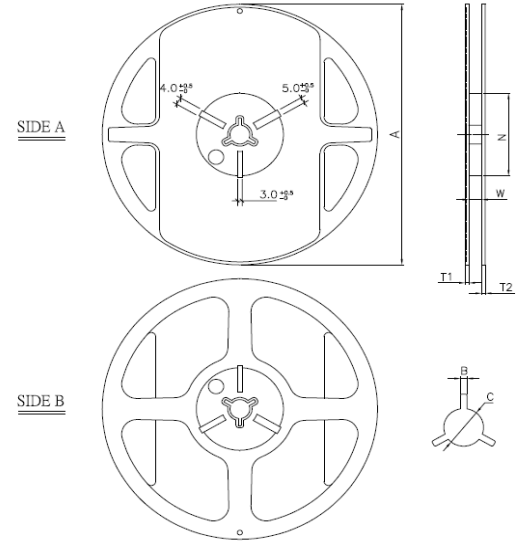

Symbol	A	B	N	W	C	T1	T2
Spec	178±5.0	2.50±1.0	60±2.0	8.40 ^{+1.50} ₀	13.0±0.5	1.10±0.3	1.65±0.3

Moisture Proof Bag

Label on the moisture proof bag consists of the following information

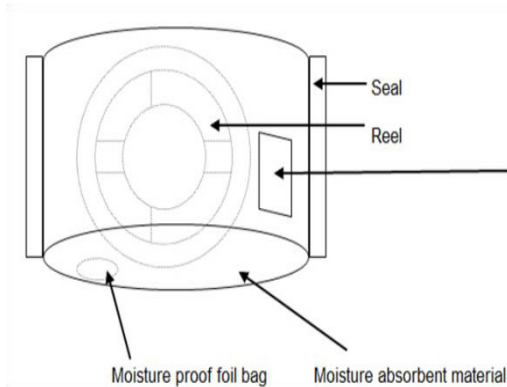

Label

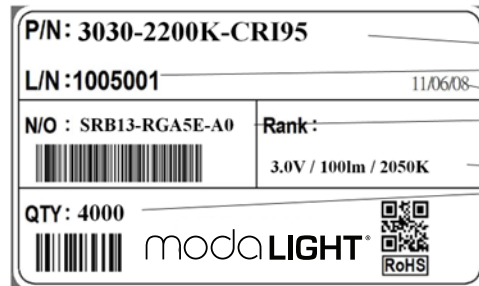

1. P/N : Part Number
2. L/N : Lot Number
3. Manufacture Date
4. N/O : Material Number (BIN Number)
5. RANK : Specification Rank
6. QTY : Quantity

Packing Unit

PACKAGE	DIMENSIONS (mm)	No. OF REEL/UNIT	QUANTITY (pcs)
Moisture Proof Bag	N/A	1 Reel/Bag	4,000 Max
Cardboard Box 25P	350 x 210 x 210 x 4t	25 Reels/Box Max	100,000 Max
Cardboard Box 50P	410 x 350 x 210 x 4t	50 Reels/Box Max	200,000 Max

NOTE 1: To avoid possible damage, it is recommended that same packing arrangement should be used.

NOTE 2: Packing tolerance is ±0.1%

RELIABILITY

TEST ITEM	TEST STANDARD	TEST CONDITIONS	FAILURE RATE
Resistance to Soldering Heat (Reflow Soldering)	JEITA ED-4701 300 301	Tsld = 260°C (10 sec), 2 times (Pre-treatment 30°C, 70%, 168 hrs)	0/50
Solder Ability (Reflow Soldering)	JEITA ED-4701 300 303	Tsld = 215+5°C (3 sec), 1 time (Lead Solder)	0/50
Thermal Shock	JEITA ED-4701 300 307	0°C (3 min) ~ 100°C (3min), 20 cycles	0/50
Temperature Cycle	JEITA ED-4701 100 105	-40°C (30min) ~ 25°C(5min) ~ 100°C(30min) ~ 25°C(5min),100 cycles	0/50
Moisture Resistance Cycle	JEITA ED-4701 200 203	25°C ~ 65°C ~ -10°C, 10 cycles 90%RH, 24 hrs./cycle	0/50
High Temperature Storage	JEITA ED-4701 200 201	Ta = 100°C 1000 hrs.	0/50
Temperature Humidity Storage	JEITA ED-4701 100 103	Ta = 60°C, RH = 90% 1000 hrs.	0/50
Lo Temperature Storage	JEITA ED-4701 200 202	Ta = -40°C 1000 hrs.	0/50
Steady State Operation Life		Ta = 25°C, If = 150 mA 1000 hrs.	0/50
Steady State Operation Life Condition II		Ta = 25°C, If = 180 mA 1000 hrs.	0/50
Steady State Operation Life of High Temperature		Ta = 85°C, If = 150 mA 1000 hrs.	0/50
Steady State Operation Life of High Humidity Heat		Ta = 60°C, RH = 90%, If = 180 mA 500 hrs.	0/50
Steady State Operation Life of Low Temperature		Ta=-30°C,If=150mA 1000 hrs.	0/50
Vibration	JEITA ED-4701 400 403	100 ~ 2000 ~ 100 Hz Sweep, 4 min. 200 m/sec ² , 3 direction, 4 cycles, 48 min.	0/50
Substrate Bending	JEITA ED-4702	3mm, 5+1 sec. 1 time	0/50
Stick	JEITA ED-4702	5N, 10+1 sec. 1 time	0/50

FAILURE CRITERIA

ITEMS	CONDITIONS	FAILURE CRITERIA
Forward Voltage	@If=180 mA, Tj=25°C	>1.1 x USL
Reverse Current	@Vr=5V, Tj=25°C	>2.0 x USL
Luminous Intensity	@If=180mA, Tj=25°C	

NOTE: Moda Light defined failure criteria as single 50% or average 35% degradation

CAUTIONS

The lifetime and performance of the LEDs are sensitive to environment and operating conditions. Cautions should be taken after due consideration when using LEDs.

(1) Moisture Proof Package SMD type LED devices are sensitive to moisture uptake. Changes of optical characteristics or contact exfoliation may be resulted from moisture uptake. Moisture proof packages are used for product delivery. It is recommended that the original moisture proof bag or similar arrangement should be used for storage after the opening of sealed packages.

(2) Storage Storage Conditions Prior to opening of the package: The LEDs should be stored in an environment with temperature less than 30°C and 50% RH or less. The shelf lifetime of unopened LEDs is six months.

After opening of the package: The storage environment should be kept at 30°C or less and 50%RH or less. The LEDs should be soldered within 24 hours (1 day) after opening the package. It is recommended to store those unused LEDs in the original moisture proof bag with moisture absorbent material. If the moisture absorbent material (silica gel) has faded away or the LEDs have exceeded the storage time, baking treatment should be performed using the following conditions

Baking treatment: More than 24 hours at 70 ± 5°C. MODALIGHT electrode and lead frame are comprised of a silver plated copper alloy. Please avoid conditions which may cause theLED to corrode, tarnish or discolor. This corrosion or discoloration might lower solder ability or might affect on optical characteristics.Please avoid rapid transitions in ambient temperature, especially in high humidity environments where condensation can occur.

(3) Heat Generation The optical characteristics of LEDs are very sensitive to temperature. Therefore, thermal design of the end product is of paramount importance. It is necessary to avoid intense heat generation and operate within the maximum ratings given in this specification.

(4) Soldering Conditions (Reference Outline)

Soldering Pad Pattern

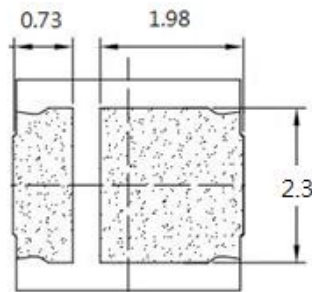

Metal Solder Stencil Aperture

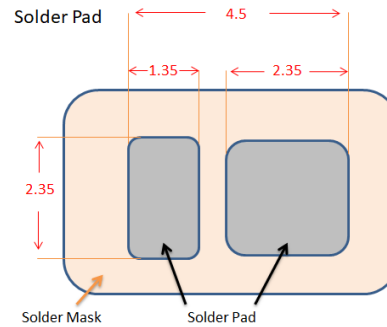

NOTE: All dimensions in mm tolerance is ± 0.1mm unless otherwise noted

Recommended Reflow Conditions

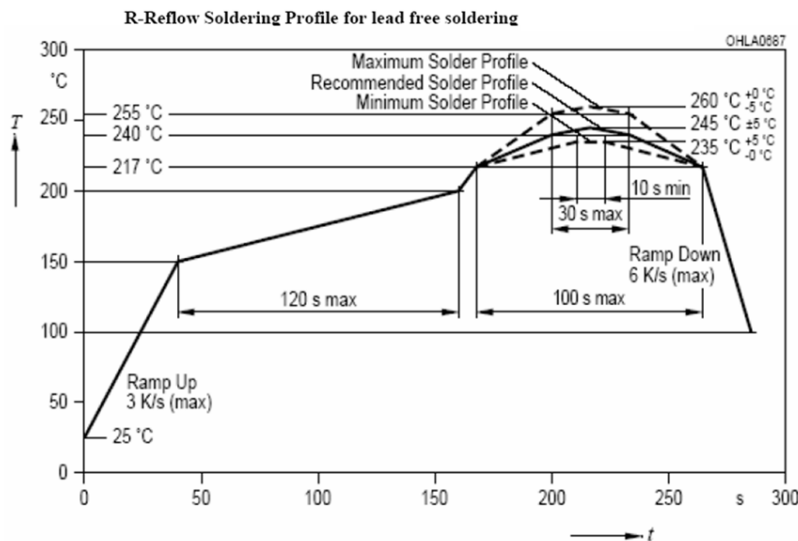

CAUTIONS

The lifetime and performance of the LEDs are sensitive to environment and operating conditions. Cautions should be taken after due consideration when using LEDs.

(5) Recommended Circuit When a parallel circuit LED driver is applied in lighting, a hot spot may occur in a low current operation (dimming mode) through the difference of the LED voltage in the low current region. In the worst case, some LED may be subjected to stresses in excess of the absolute maximum rating. It is recommended to use **Circuit A** which regulates the current flowing.

Circuit A: Recommended Circuit

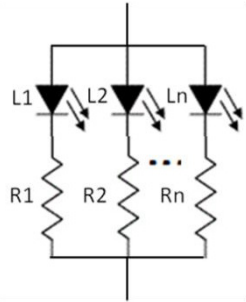

Separate resistor per each LED

Circuit B: Abnormal Circuit

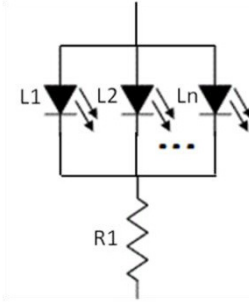

Easy to occur brightness problem

Circuit C: Abnormal Circuit

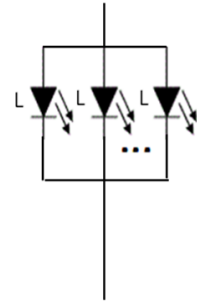

Easy to occur brightness problem

(6) Cleaning It is recommended to clean the LEDs using Isopropyl alcohol. When using other solvents, it should be confirmed beforehand whether the solvents will dissolve the package and the resin or not. Freon solvents should not be used to clean the LEDs because of worldwide regulations. Never clean the LEDs with the ultrasonic machines.

(7) Static Electricity Static electricity or surge voltage will damage the LEDs. It is recommended that a wrist band or an anti-electrostatic glove be used when handling the LEDs. All devices, equipment and machinery must be properly grounded. It is recommended that measures be taken against surge voltage to the equipment that mounts the LEDs. When inspecting the final products in which LEDs were assembled, it is recommended to check whether the assembled LEDs are damaged by static electricity or not. It is easy to find static damaged LEDs by a light-on test or a VF test at a lower current (below 1mA is recommended). Damaged LEDs will show some unusual characteristics such as the leak current remarkably increases, the forward voltage becomes lower, or the LEDs do not illuminate at low current.

Criteria: (Vf > 2.0V at If = 0.5mA)

(8) Others Care must be taken to ensure that the reverse voltage will not exceed the absolute maximum rating when using the LEDs with matrix drive. The LED light output is strong enough to injure human eyes. Precautions must be taken to prevent looking directly at the LEDs with unaided eyes for more than a few seconds. Flashing lights have been known to cause discomfort in people: you can prevent this by taking precautions during use. Also, users should be cautious when using equipment that has had LEDs incorporated into it. The LEDs described in this brochure are intended to be used for ordinary electronic equipment. LED devices used in applications in which exceptional quality and reliability are required, particularly when the failure or malfunction of the LEDs may directly jeopardize life or health, must be expressly authorized. Due to the special conditions of the manufacturing processes of LED, the typical data or calculated correlations of technical parameters can only reflect statistical figures. These do not necessarily correspond to the actual parameters of each single product, which could differ from the typical data and calculated correlations or the typical characteristic line. If requested, e.g. because of technical improvements, these typical data will be changed without any further notice.