

1 Mount ZUBA Xtrusion to drywall.

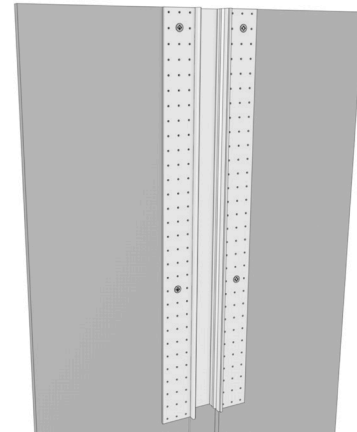

2 Align and mount ZUBA Xtrusions for continuous run.

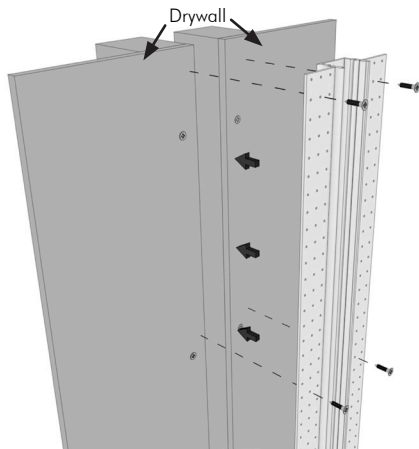
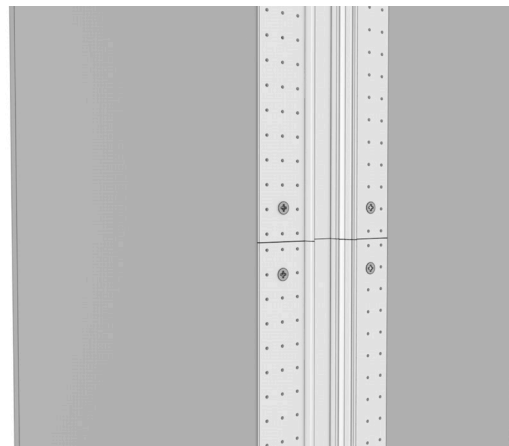
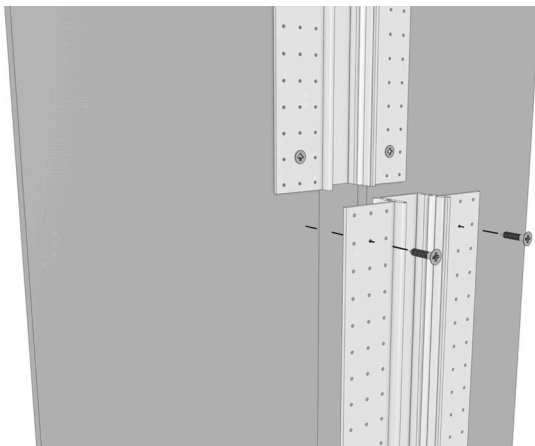

3 Drill 1/2" holes into bottom of ZUBA Xtrusion to feed product cables through.

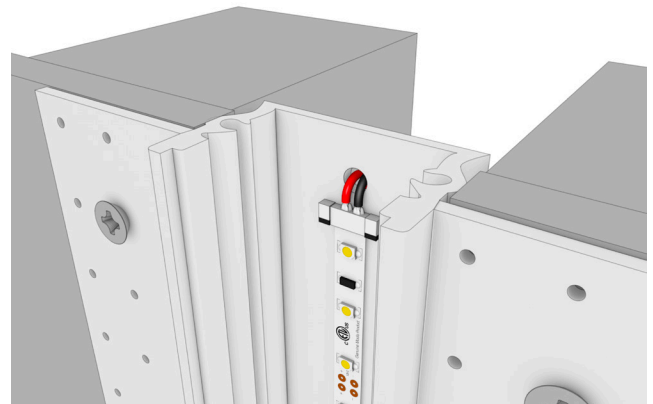
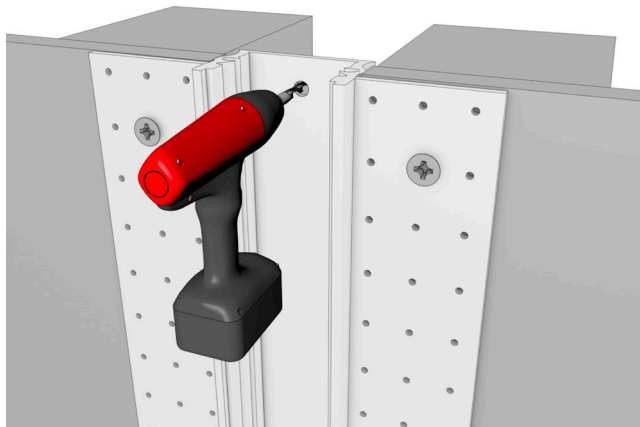

modaLIGHT® INSTALLATION

- 4 Remove backing from 3M tape on back of product and place in ZUBA Xtrusion.

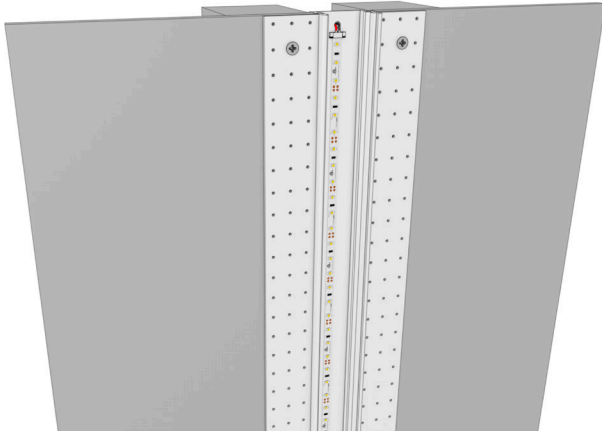

- 5 Wiring

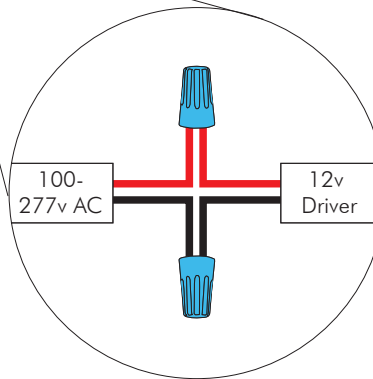
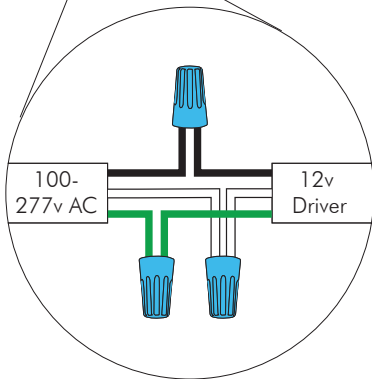

UL / cUL Non-dimming



UL / cUL ELV Dimming

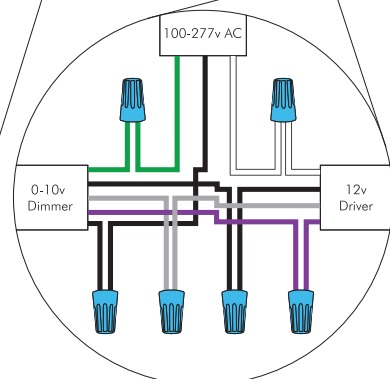
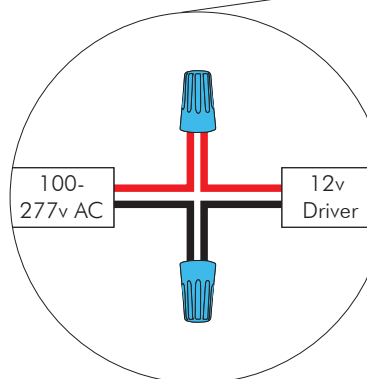

modaLIGHT® INSTALLATION

7 Place Diffuser onto ZUBA Xtrusion

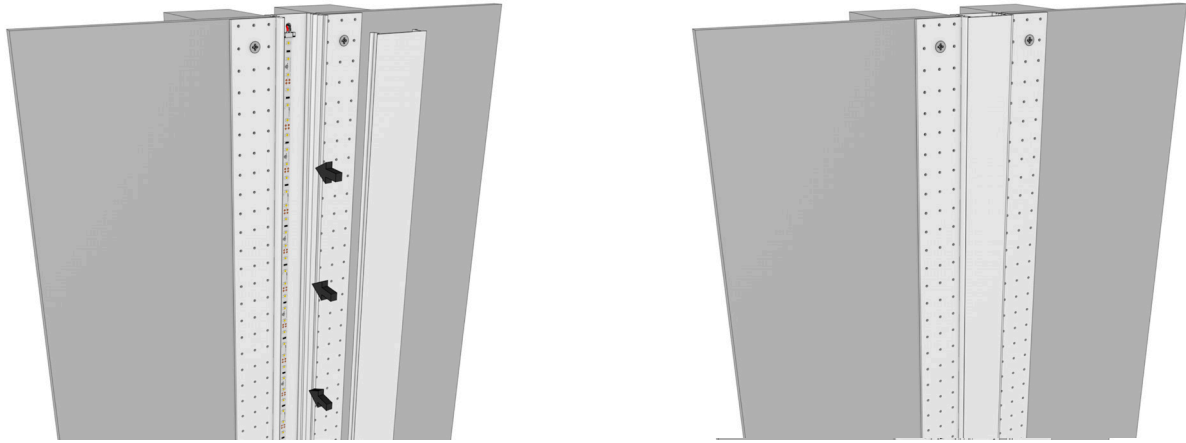

8 Screw End Caps into ZUBA Xtrusion.

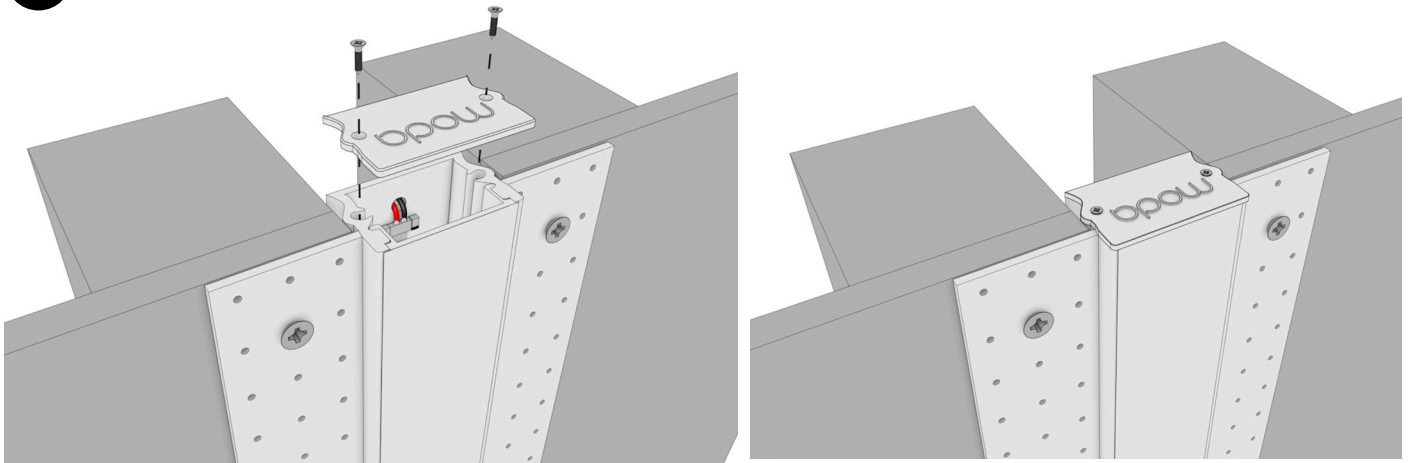

9 Mud over screws and sides of ZUBA Xtrusion.

- Sandpaper dried mud to even out
- Paint over dried mud

